

Howard B. Mattlin Middle School

Incoming Grade 7

Parent Transition Meeting

March 7, 2016

Meeting Overview

- 7th Grade Transition - Student Perspective
- Availability of Core and Special Area Classes
- Options for Acceleration
- Course Recommendations and Self Selection
- Overview of Various Student Programs
- 7th & 8th Grade Athletics
- 1:1 Update
- Options for Additional Support During Zero and 9th Period

Chris Donarummo, Principal

Beth Torreano, Assistant Principal (Grades 6 & 8)

Andrea Luzzi, Guidance Counselor

Lenore Shalom, School Nurse

6th to 7th Grade Transition
Student Perspective

Benjamin Yacht

7th Grade Class President

Overview of 7th Grade Courses

Core Area Subjects:

- English
- Mathematics (Math 7 or Math 7 Accelerated)
- Social Studies
- Science
- World Language (Chinese, French or Spanish)

Special Area Subjects:

- Technology (Every Day – Semester)
- Family & Consumer Science (Every Day –Semester)
- Physical Education (Every Other Day - Full Year)
- General Music & Art (Every Other Day – Semester)

Optional Acceleration for 7th Grade

Math Courses

Mathematics 7 Accelerated

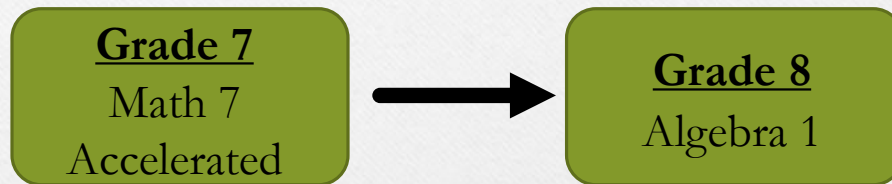

Mathematics 7

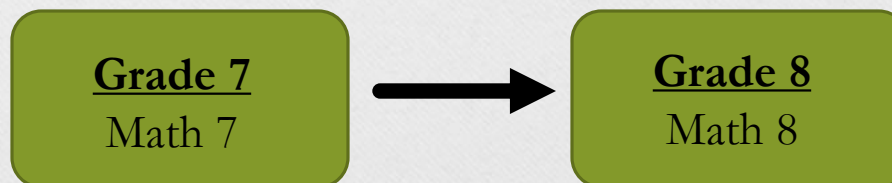

Mathematics

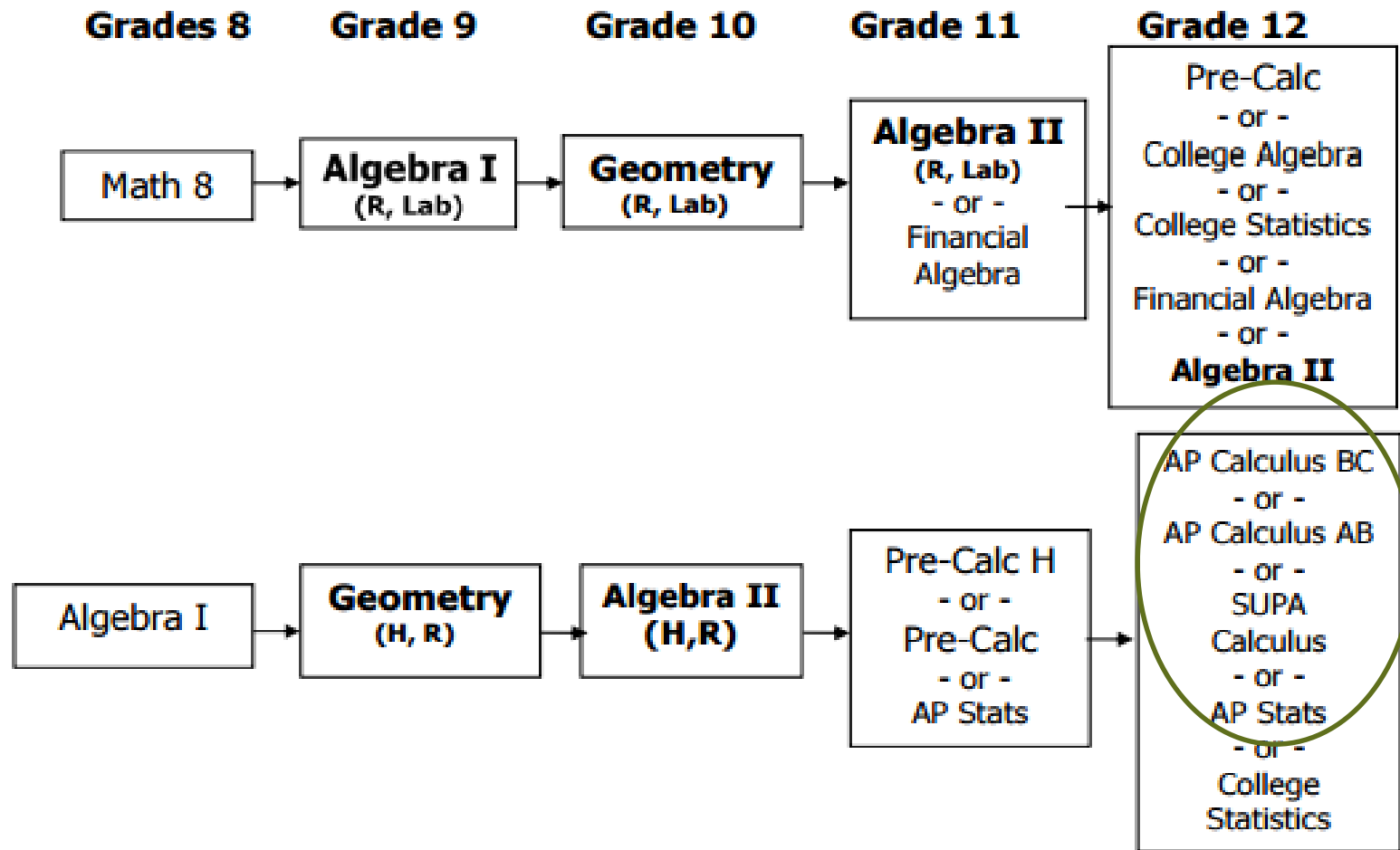

How will I know the recommendations for my child?

Course Verification Forms

- All parents/guardians will receive printed course verification forms in the mail on or about **March 7, 2016**
- Forms must be signed and returned to the Guidance Office at Mattlin Middle School by **April 1, 2016**
- Parents have the opportunity to discuss the recommendation with the teacher and guidance counselor
- All information will also be available on the Portal

Course Verification Form

Grade: 07

Required Courses:

- 702 ART 7
- 712 ENGLISH 7
- 704 FAMILY & CONSUMER SCIENCE 7
- 701 GEN MUSIC 7
- 706 LUNCH 7
- 722 MATH 7 ACCELERATED
- 705 PHYS ED 7
- 740 SCIENCE 7
- 730 SOC STUDIES 7
- 750 SPANISH 7
- 766 STRING ORCH 6/7/8
- 703 TECHNOLOGY 7

Parent/Guardian Signature _____ **Date** _____

What is Self-Selection?

- Opportunity to enroll in an accelerated course when not recommended
 - ✓ Conversation with the student
 - ✓ Conversation with teacher and guidance counselor
- What is the process for self-selection?
 - ✓ Complete and return a Self-Selection form for each accelerated course
 - ✓ Form must be returned by April 1, 2016



Excellence in Education

HOWARD B. MATTLIN MIDDLE SCHOOL
SELF-SELECTION FORM
2016-2017



Student's First Name

Student's Last Name

Grade in 2015-2016

I would like to self-select my child into the accelerated course circled below. I realize that this was not the recommended course for my child for the upcoming school year. I am also aware that if my child does not perform well in this course and needs a change in placement during the school year, this could significantly impact his/her schedule.

Accelerated Course Offerings – Grade 7

722 Math 7 Accelerated

Accelerated Course Offerings – Grade 8

301 Algebra 1

403-1 Earth Science + Lab

801/903 Studio Art

Parent's Signature

Date

Student's Signature

**This form must be returned to the guidance office
no later than Friday, April 1, 2016.**

Typical Schedule

1	740-5 SCIENCE 7 Burke, J. Rm: C2 Team: 7B	740-5 SCIENCE 7 Burke, J. Rm: C2 Team: 7B	740-5 SCIENCE 7 Burke, J. Rm: C2 Team: 7B	740-5 SCIENCE 7 Burke, J. Rm: C2 Team: 7B
2	730-4 SOC STUDIES 7 Benjamin/Dubrow Rm: C31 Team: 7B	730-4 SOC STUDIES 7 Benjamin/Dubrow Rm: C31 Team: 7B	730-4 SOC STUDIES 7 Benjamin/Dubrow Rm: C31 Team: 7B	730-4 SOC STUDIES 7 Benjamin/Dubrow Rm: C31 Team: 7B
3	750-5 SPANISH 7 Yanch, K. Rm: D25	750-5 SPANISH 7 Yanch, K. Rm: D25	750-5 SPANISH 7 Yanch, K. Rm: D25	750-5 SPANISH 7 Yanch, K. Rm: D25
4	703-5 TECHNOLOGY 7 Olitsky, D. Rm: TCHA	703-5 TECHNOLOGY 7 Olitsky, D. Rm: TCHA	704-5 FAMILY & CONSUMER SCIENCE 7 Epstein, S. Rm: FCS-B	704-5 FAMILY & CONSUMER SCIENCE 7 Epstein, S. Rm: FCS-B
5	720-3 MATH 7 Zaccoli/Dubrow Rm: C25 Team: 7B	720-3 MATH 7 Zaccoli/Dubrow Rm: C25 Team: 7B	720-3 MATH 7 Zaccoli/Dubrow Rm: C25 Team: 7B	720-3 MATH 7 Zaccoli/Dubrow Rm: C25 Team: 7B
6	706-1 LUNCH 7 Rm: CAFE	706-1 LUNCH 7 Rm: CAFE	706-1 LUNCH 7 Rm: CAFE	706-1 LUNCH 7 Rm: CAFE
7	705-7 (1, 3, 5) PHYS ED 7 Gasbarro, R. Rm: GYM	705-7 (1, 3, 5) PHYS ED 7 Gasbarro, R. Rm: GYM	705-7 (1, 3, 5) PHYS ED 7 Gasbarro, R. Rm: GYM	705-7 (1, 3, 5) PHYS ED 7 Gasbarro, R. Rm: GYM
	701-7 (2, 4, 6) GEN MUSIC 7 Lucas, E. Rm: ORCH Start: 09/10/2015	701-7 (2, 4, 6) GEN MUSIC 7 Lucas, E. Rm: ORCH	702-7 (2, 4, 6) ART 7 Curran, L. Rm: FCS-C	702-7 (2, 4, 6) ART 7 Curran, L. Rm: FCS-C
8	712-1 ENGLISH 7 Curran, D./Dubrow, S. Rm: C27 Team: 7B	712-1 ENGLISH 7 Curran, D./Dubrow, S. Rm: C27 Team: 7B	712-1 ENGLISH 7 Curran, D./Dubrow, S. Rm: C27 Team: 7B	712-1 ENGLISH 7 Curran, D./Dubrow, S. Rm: C27 Team: 7B

Math 7 or Math 7 Accelerated

1	722-1 MATH 7 ACCELERATED Zaccoli, F. Rm: C25 Team: 7B	722-1 MATH 7 ACCELERATED Zaccoli, F. Rm: C25 Team: 7B	722-1 MATH 7 ACCELERATED Zaccoli, F. Rm: C25 Team: 7B	722-1 MATH 7 ACCELERATED Zaccoli, F. Rm: C25 Team: 7B
2	730-4 SOC STUDIES 7 Benjamin/Dubrow Rm: C31 Team: 7B	730-4 SOC STUDIES 7 Benjamin/Dubrow Rm: C31 Team: 7B	730-4 SOC STUDIES 7 Benjamin/Dubrow Rm: C31 Team: 7B	730-4 SOC STUDIES 7 Benjamin/Dubrow Rm: C31 Team: 7B
3	705-2 (1, 3, 5) PHYS ED 7 Pluschau, P. Rm: GYM 701-2 (2, 4, 6) GEN MUSIC 7 Catalano, C. Rm: MUSB	705-2 (1, 3, 5) PHYS ED 7 Pluschau, P. Rm: GYM 701-2 (2, 4, 6) GEN MUSIC 7 Catalano, C. Rm: MUSB	705-2 (1, 3, 5) PHYS ED 7 Pluschau, P. Rm: GYM 702-2 (2, 4, 6) ART 7 Goscinski, M. Rm: C6	705-2 (1, 3, 5) PHYS ED 7 Pluschau, P. Rm: GYM 702-2 (2, 4, 6) ART 7 Goscinski, M. Rm: C6
4	703-5 TECHNOLOGY 7 Olitsky, D. Rm: TCHA	703-5 TECHNOLOGY 7 Olitsky, D. Rm: TCHA	704-5 FAMILY & CONSUMER SCIENCE 7 Epstein, S. Rm: FCS-B	704-5 FAMILY & CONSUMER SCIENCE 7 Epstein, S. Rm: FCS-B
5	740-2 SCIENCE 7 Burke, J. Rm: C2 Team: 7B	740-2 SCIENCE 7 Burke, J. Rm: C2 Team: 7B	740-2 SCIENCE 7 Burke, J. Rm: C2 Team: 7B	740-2 SCIENCE 7 Burke, J. Rm: C2 Team: 7B
6	706-1 LUNCH 7 Rm: CAFE	706-1 LUNCH 7 Rm: CAFE	706-1 LUNCH 7 Rm: CAFE	706-1 LUNCH 7 Rm: CAFE
7	750-4 SPANISH 7 Schaefer, M. Rm: D26	750-4 SPANISH 7 Schaefer, M. Rm: D26	750-4 SPANISH 7 Schaefer, M. Rm: D26	750-4 SPANISH 7 Schaefer, M. Rm: D26
8	712-1 ENGLISH 7 Curran, D./Dubrow, S. Rm: C27 Team: 7B	712-1 ENGLISH 7 Curran, D./Dubrow, S. Rm: C27 Team: 7B	712-1 ENGLISH 7 Curran, D./Dubrow, S. Rm: C27 Team: 7B	712-1 ENGLISH 7 Curran, D./Dubrow, S. Rm: C27 Team: 7B

Resource Room

1	740-3 SCIENCE 7 Gonzalez, Y. Rm: C3 Team: 7A	740-3 SCIENCE 7 Gonzalez, Y. Rm: C3 Team: 7A	740-3 SCIENCE 7 Gonzalez, Y. Rm: C3 Team: 7A	740-3 SCIENCE 7 Gonzalez, Y. Rm: C3 Team: 7A
2	781-1 RESOURCE ROOM 7 Mento, C. Rm: C28	781-1 RESOURCE ROOM 7 Mento, C. Rm: C28	781-1 RESOURCE ROOM 7 Mento, C. Rm: C28	781-1 RESOURCE ROOM 7 Mento, C. Rm: C28
3	705-1 (1, 3, 5) PHYS ED 7 Homan, L. Rm: GYM <hr/> 701-2 (2, 4, 6) GEN MUSIC 7 Catalano, C. Rm: MUSB	705-1 (1, 3, 5) PHYS ED 7 Homan, L. Rm: GYM <hr/> 701-2 (2, 4, 6) GEN MUSIC 7 Catalano, C. Rm: MUSB	705-1 (1, 3, 5) PHYS ED 7 Homan, L. Rm: GYM <hr/> 702-2 (2, 4, 6) ART 7 Goscinski, M. Rm: C6	705-1 (1, 3, 5) PHYS ED 7 Homan, L. Rm: GYM <hr/> 702-2 (2, 4, 6) ART 7 Goscinski, M. Rm: C6
4	712-3 ENGLISH 7 Catterson, L. Rm: C29 Team: 7A	712-3 ENGLISH 7 Catterson, L. Rm: C29 Team: 7A	712-3 ENGLISH 7 Catterson, L. Rm: C29 Team: 7A	712-3 ENGLISH 7 Catterson, L. Rm: C29 Team: 7A
5	720-2 MATH 7 Cardone, D. Rm: C21 Team: 7A	720-2 MATH 7 Cardone, D. Rm: C21 Team: 7A	720-2 MATH 7 Cardone, D. Rm: C21 Team: 7A	720-2 MATH 7 Cardone, D. Rm: C21 Team: 7A
6	706-1 LUNCH 7 Rm: CAFE	706-1 LUNCH 7 Rm: CAFE	706-1 LUNCH 7 Rm: CAFE	706-1 LUNCH 7 Rm: CAFE
7	750-6 SPANISH 7 Falbo, K. Rm: D23	750-6 SPANISH 7 Falbo, K. Rm: D23	750-6 SPANISH 7 Falbo, K. Rm: D23	750-6 SPANISH 7 Falbo, K. Rm: D23
8	730-8 SOC STUDIES 7 Maiello, J. Rm: C30 Team: 7A	730-8 SOC STUDIES 7 Maiello, J. Rm: C30 Team: 7A	730-8 SOC STUDIES 7 Maiello, J. Rm: C30 Team: 7A	730-8 SOC STUDIES 7 Maiello, J. Rm: C30 Team: 7A

English/AIS Lab

1	730-2 SOC STUDIES 7 Maiello, J. Rm: C30 Team: 7A	730-2 SOC STUDIES 7 Maiello, J. Rm: C30 Team: 7A	730-2 SOC STUDIES 7 Maiello, J. Rm: C30 Team: 7A	730-2 SOC STUDIES 7 Maiello, J. Rm: C30 Team: 7A
2	750-2 SPANISH 7 Falbo, K. Rm: D23	750-2 SPANISH 7 Falbo, K. Rm: D23	750-2 SPANISH 7 Falbo, K. Rm: D23	750-2 SPANISH 7 Falbo, K. Rm: D23
3	703-3 TECHNOLOGY 7 Courtesis, L. Rm: TECC	703-3 TECHNOLOGY 7 Courtesis, L. Rm: TECC	704-3 FAMILY & CONSUMER SCIENCE 7 Epstein, S. Rm: FCS-B	704-3 FAMILY & CONSUMER SCIENCE 7 Epstein, S. Rm: FCS-B
4	712-3 ENGLISH 7 Catterson, L. Rm: C29 Team: 7A	712-3 ENGLISH 7 Catterson, L. Rm: C29 Team: 7A	712-3 ENGLISH 7 Catterson, L. Rm: C29 Team: 7A	712-3 ENGLISH 7 Catterson, L. Rm: C29 Team: 7A
5	740-7 SCIENCE 7 Gonzalez, Y. Rm: C3 Team: 7A	740-7 SCIENCE 7 Gonzalez, Y. Rm: C3 Team: 7A	740-7 SCIENCE 7 Gonzalez, Y. Rm: C3 Team: 7A	740-7 SCIENCE 7 Gonzalez, Y. Rm: C3 Team: 7A
6	706-1 LUNCH 7 Rm: CAFE	706-1 LUNCH 7 Rm: CAFE	706-1 LUNCH 7 Rm: CAFE	706-1 LUNCH 7 Rm: CAFE
7	705-7 (1, 3, 5) PHYS ED 7 Gasbarro, R. Rm: GYM 8601-1 (2, 4, 6) ENGLISH LAB 7 Catterson, L. Rm: C29	705-7 (1, 3, 5) PHYS ED 7 Gasbarro, R. Rm: GYM 8601-1 (2, 4, 6) ENGLISH LAB 7 Catterson, L. Rm: C29	705-7 (1, 3, 5) PHYS ED 7 Gasbarro, R. Rm: GYM 8601-1 (2, 4, 6) ENGLISH LAB 7 Catterson, L. Rm: C29	705-7 (1, 3, 5) PHYS ED 7 Gasbarro, R. Rm: GYM 8601-1 (2, 4, 6) ENGLISH LAB 7 Catterson, L. Rm: C29
8	722-3 MATH 7 ACCELERATED Cardone, D. Rm: C21 Team: 7A	722-3 MATH 7 ACCELERATED Cardone, D. Rm: C21 Team: 7A	722-3 MATH 7 ACCELERATED Cardone, D. Rm: C21 Team: 7A	722-3 MATH 7 ACCELERATED Cardone, D. Rm: C21 Team: 7A

The World of Middle School Sports

Lenore Shalom, R.N.

Interscholastic Sports: Grades 7&8

- ✓ Various middle school sport teams throughout Long Island, each representing a particular school and sport
- ✓ Your child and his/her team will have a chance to represent the POB school district

Why Join a Team?

Promotes the physical, social, emotional, and psychological well being of students

- ✓ Relieves stress
- ✓ Promotes exercise
- ✓ Improves athletic proficiency
- ✓ Encourages discipline, concentration, focus, and time management
- ✓ A shared team experience
- ✓ Socialization
- ✓ Raises self esteem
- ✓ Leads to positive academic achievement

Why Join a Team?

“Regular physical activity in childhood and adolescence improves strength, endurance, helps build healthy bones and muscles, increases self esteem, and helps to improve blood pressure and cholesterol levels.”

- Center for Disease Control (CDC) on school health

Sports Schedules – Four Seasons

Fall Season

Sept. 8th – Nov. 1st

- ✓ Football
- ✓ Boys' Soccer
- ✓ Boys' Tennis
- ✓ Girls' Swimming
- ✓ Girls' Soccer
- ✓ Cheerleading
- ✓ Coed Cross Country

Winter 1 Season

Nov. 5th – Jan. 14th

- ✓ Boys' Basketball
- ✓ Boys' Swimming
- ✓ Girls' Volleyball
- ✓ Cheerleading

Sports Schedules

Winter 2 Season

Jan. 20th - March 20th

- ✓ Boys' Volleyball
- ✓ Girls' Volleyball
- ✓ Wrestling
- ✓ Coed Bowling

Spring Season

March 30th - June 4th

- ✓ Boys' Track
- ✓ Boys' Lacrosse
- ✓ Baseball
- ✓ Girls' Track
- ✓ Girls' Lacrosse
- ✓ Girls' Tennis
- ✓ Softball

Sports Routine

- ✓ Daily practices and/or games
- ✓ Starts at the end of the school day
- ✓ Practice - transportation to location and parental pick up required
- ✓ Games - travel to location and return on bus with team

Obtaining Sports Registration Forms

- ✓ Go to POB website
- ✓ Departments
- ✓ Athletics – click on forms
- ✓ <http://www.pob.k12.ny.us/Page/3409>
- ✓ Print first 3 links
 - **POB Interscholastic Participation Contract**
 - ❖ Must be signed by parent and student
 - **POB Concussion Information Sheet**
 - ❖ Must be signed by parent and student
 - **POB Athletic Physical Form**
 - ❖ Must be completed by physician
 - ❖ Valid for one year from date signed
 - ❖ Fulfills 7th grade requirement for physical exam

Sports Registration Procedure

- ✓ Announcement 2 weeks before season starts
- ✓ Completed forms to be brought to health office by announced deadline
- ✓ Nurse will sign interscholastic participation contract
- ✓ Concussion form and contract to be brought to coach first day of tryouts

Points to Remember

- ✓ Each sport requires a new form
- ✓ Medication not used during school hours requires physician's order and medication to be given to the coach (i.e., inhalers, epi pens, over the counter)
- ✓ If student absent or leaves school before end of the day, he/she may not participate in sports
- ✓ Medical excuses and/or clearance can only be given by physician

How to support your child?

- ✓ Your encouragement, support, and insistence on good health habits
 - Don't have to be the best athlete in the world!
- ✓ Nutritious breakfast & lunch each day and a good night's sleep
- ✓ 7th grade physical mandated by NYS Department of Education

1:1 Initiative Update

Parent/Student Informational Meeting

Monday, March 21, 2016 @ 5:30 pm -5th Grade

Tuesday, March 22, 2016 @ 6:45 pm – 6th Grade

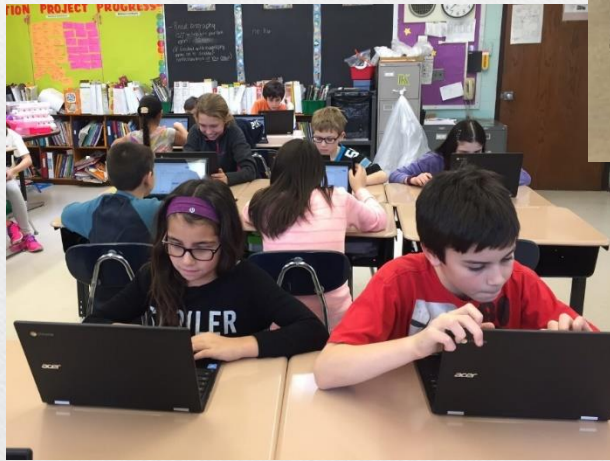

Additional Opportunities Available During Zero Period

Zero Period

- Clubs
- ELA AIS
- Math AIS

Ninth Period

- Remedial (Tuesday, Thursday and Wednesday for special area classes)

Successful 2016/2017 School Year

- Construct a program of courses that is appropriate
- Acceleration in all courses is not always the best option
- Take into account course recommendations prior to Self-Selecting
- Continually monitor the information on the Portal
- Teacher Contact (Phone, E-mail & Team Meetings)
- Join and attend PTA Meetings
- Open door policy
- Encourage the use of remedial whenever possible

Questions and/or Concerns